

Geberit Installation System for 1.28/0.8 GPF (4.8/3 LPF) Wall-Hung Toilets, 2 x 6 Installations

Product Specifications

In-Wall Duofix carrier system and Sigma concealed tank with actuator flush panel or pneumatic push button for washdown wall-hung toilets. System shall fit within minimum 5 1/2" (146 mm) framing wall or plumbing chase, with wood construction or steel framing members placed 19 3/4" (500 mm) apart. Framing members should be capable of supporting a 880 pound (400 kg) load without damage to the wall. Water supply shall have flow diameter no smaller than 1/2" (13 mm) copper tube, and a minimum flow pressure of 2 PSI (0.01 MPa). The in-wall system shall only be paired with a toilet bowl that is a third party listed low-consumption 1.28 GPF (4.8 LPF) or 1.28/0.8 GPF (4.8/3 LPF) dual-flush 2-hole wall-hung type. The carrier frame shall be adjustable for bowl rim heights from 15" to 19" (381 to 483 mm). Actuator flush panels shall be diecast zinc, molded plastic or fabricated stainless steel and plated to preserve material integrity. All components shall be compliant with applicable codes and product standards.

Warranty

Limited lifetime warranty on tank and carrier, 10-year warranty on fill valve and flush valve. One-year warranty on actuator flush plates.

Features

- Water consumption – Dual-flush system allows 1.28/0.8 GPF (4.8/3 LPF), giving effective flush volume of 1 GPF (3.8 LPF)
- Anti-siphon fill valve
- Impact resistant high density polyethylene (HDPE) tank, insulated to prevent condensation
- 16-gauge, powder-coated, structural-steel tubing rated to 880 lbs. (400 kg) without damage to finished wall or carrier unit
- Bowl rim height adjustments from 15" to 19" (381 to 483 mm)
- 49" (1245 mm) frame height
- For finished walls up to 5 1/2" (14cm) thick
- For use with Geberit Sigma actuator plates (not included)
- Includes installation and rough-in materials

Complies with the latest editions of:

- ASME: A112.6.2, A112.19.5
- ANSI Z124.4
- CSA B125.3
- ANSI/ASSE 1002
- IAPMO PS-50
- UNAR / UNAR-HET
- ASME A112.19.2
- This concealed tank is WaterSense® compliant when used in combination with the toilet bowl models listed on page 2 of this sheet.
- State of Massachusetts (pending)*
- cUPC listed
- IPC listed
- CEC listed

Model No.	Description	
111.902.00.5	Geberit Duofix Carrier with Sigma Concealed Tank, 2 x 6 installations for wall-hung toilets	

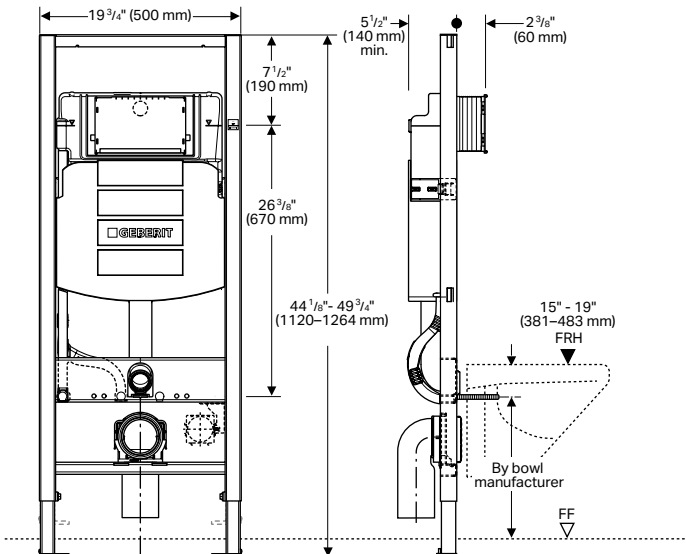

Products marked with comply with the American Disabilities Act (ADA) when installed per the requirements of the latest ADA Accessibility Guidelines (ADAAG) and/or ICC/ANSI A117.1.

Where water closet grab bars are required and corresponding reinforcement provided as outlined in the latest NYC Building Code and Federal FHA Guidelines, the installed product complies both for grab bars installed at the time of initial construction as well as for grab bars planned for future installation.



ARCHITECT/ENGINEER APPROVAL

Job Name _____

Date _____ Quantity _____

Model Specified _____

Variations Specified _____

Customer/Wholesaler _____

Contractor _____

Architect _____

Geberit Installation System for 1.28/0.8 GPF (4.8/3 LPF) Wall-Hung Toilets, 2 x 6 Installations

WaterSense® Compliant EPA High Efficiency Compatible Wall-Hung Toilet Bowl Models

Brand	Model Number*	Model Name
TOTO	CT437FG	MH
	CT437FT20G	MH Connect+

The product combinations listed meet the criteria of the WaterSense Specification for Tank-Type Toilets but are not listed on the WaterSense website at this time.

Geberit
2100 S. Clearwater Drive
Des Plaines, IL 60018
USA

P 800-566-2100
F 847-803-5454

→ geberit.us